

Weigh Module



FEATURES

- Capacity range: 5, 10, 20, 50, and 100 kN (1.12K, 2.25K, 4.5K, 11.2K, and 22.5K lb)
- Simple installation
- Moveable load point
- Withstands very high lateral forces
- Extremely accurate and rugged
- ATEX certified for hazardous locations

DESCRIPTION

The KIS-9 load cell has several features that clearly distinguish it from other load cells. It is easy to install and extremely accurate, even when subjected to vibration forces and severe environmental conditions. All KIS load cells can be ATEX certified for use in explosive atmospheres.

APPLICATIONS

- Silo, bin and hopper weighing
- Inventory control systems
- Industrial conveyors
- Force measurement systems

OUTLINE DIMENSIONS

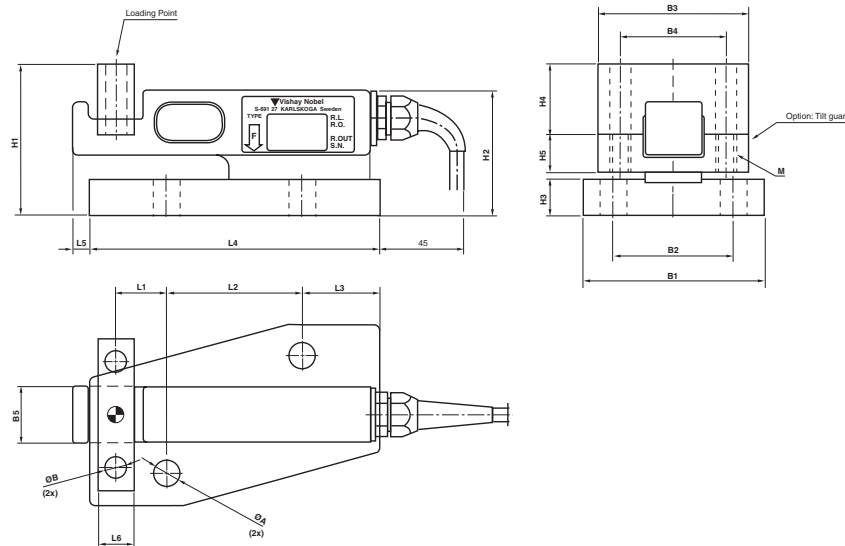

RANGE kN	L1	L2	L3	L4	L5	L6	ØA	ØB
5-10-20	27	72	41	154	9	19	14	11
50	38	80	48	185	14	29	18	18
100	48	122	25	220	17	48	22	22

RANGE kN	B1	B2	B3	B4	B5	H1	H2	H3	H4	H5	M
5-10-20	96	62	80	56	30	80	67	19	37	20.5	M10
50	128	88	128	88	48	115	93	33	48	28	M16
100	160	120	160	120	62	130	108	38	53	33	M20

INSTALLATION EXAMPLES

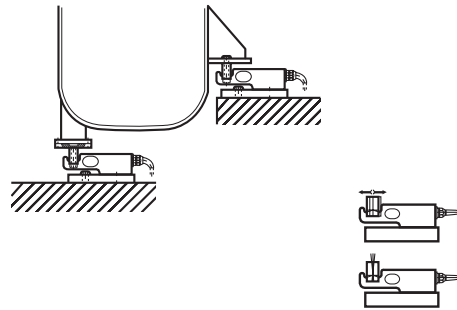

SPECIFICATIONS

Rated load (R.L.)		5, 10, 20, 50, 100	kN
Combined error (terminal)		± 0.1	% of R.O.
Repeatability		0.02	% of R.O.
Overload	safe	50*	% of R.L.
	ultimate	100*	% of R.L.
Sideload	ultimate	100*	% of R.L.
Input voltage	recommended	10	V DC or AC
	maximum	18	V DC or AC
Input resistance		350 ± 5	ohm
Output resistance		350 ± 1	ohm
Rated output (R.O.)		1.020	mV/V
Tolerance of R.O.		± 0.25	% of R.O.
Zero balance		± 2	% of R.O.
Tolerance of shunt calibration values		± 0.25	% of value**
Creep at R.L. after 30 minutes		± 0.03	% of R.L.
Temperature range		- 40 to + 80 (+ 100)***	°C
Temperature effect (- 10°C to + 50°C)	on output	± 0.003	% of output/°C
	on zero balance	± 0.003	% of R.O./°C
Insulation resistance at 200 V DC		> 4	Gohm
Material		Stainless steel	
Electrical connection		5 m shielded four conductor cable	5, 10, 20 kN
		10 m shielded four conductor cable	50, 100 kN
Degree of protection		IP 67	
*Referring to recommended loading case		ATEX certified versions for use in explosive atmosphere are available	
** See calibration sheet of the load cell		II 1GD	
*** - 40 to + 100°C on demand			

Disclaimer

All product specifications and data are subject to change without notice.

Vishay Precision Group, Inc., its affiliates, agents, and employees, and all persons acting on its or their behalf (collectively, "Vishay Precision Group"), disclaim any and all liability for any errors, inaccuracies or incompleteness contained herein or in any other disclosure relating to any product.

Vishay Precision Group disclaims any and all liability arising out of the use or application of any product described herein or of any information provided herein to the maximum extent permitted by law. The product specifications do not expand or otherwise modify Vishay Precision Group's terms and conditions of purchase, including but not limited to the warranty expressed therein, which apply to these products.

No license, express or implied, by estoppel or otherwise, to any intellectual property rights is granted by this document or by any conduct of Vishay Precision Group.

The products shown herein are not designed for use in medical, life-saving, or life-sustaining applications unless otherwise expressly indicated. Customers using or selling Vishay Precision Group products not expressly indicated for use in such applications do so entirely at their own risk and agree to fully indemnify Vishay Precision Group for any damages arising or resulting from such use or sale. Please contact authorized Vishay Precision Group personnel to obtain written terms and conditions regarding products designed for such applications.

Product names and markings noted herein may be trademarks of their respective owners.